

Optional 24" Cast Iron  
Frame & Cover

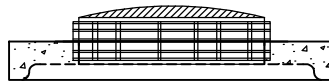

24" Diameter  
Plastic Tuff Tite Extension  
Cast In

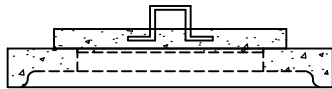
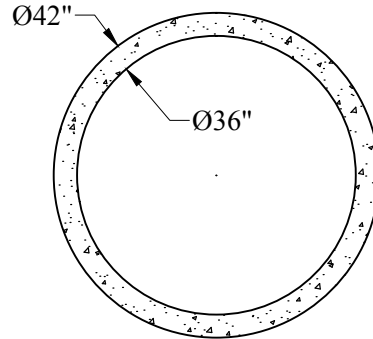

Optional 24" Plug

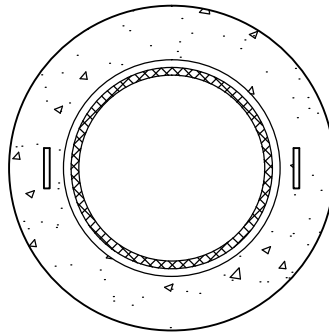

24" Diameter  
Plastic Tuff Tite Extension  
Cast In

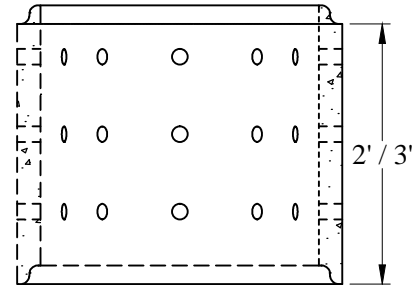

Perforated Tile

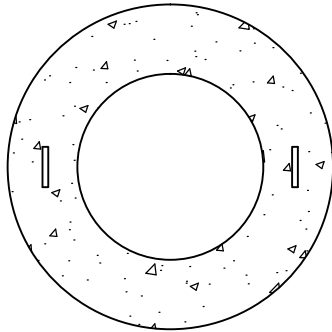

24" Opening

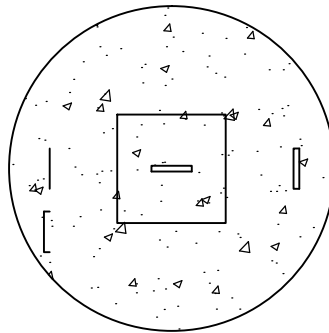

14" X 14" Plug

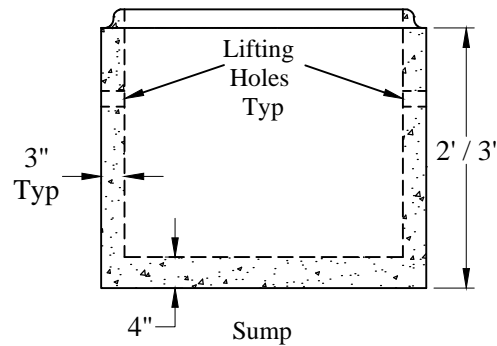

Item	Weight	P/N:
24" Opening Cover	400 lbs	DWC-42CL
24" Opening Cover w/ Hatch	400 lbs	DWC-42CLP
14"x14" Opening Cover	400 lbs	DWC-14X14CL
3' Riser	1,135 lbs	DWR-3X3
2' Riser	760 lbs	DWR-3X2
3' Sump	1,420 lbs	DWS-3X3
2' Sump	1,105 lbs	DWS-3X2

**General Notes**

- 1.) Reinforcement Steel Conforms to Latest ASTM Specifications:  
ASTM A185 and ASTM A615 Grade 60 Rebar
- 2.) Concrete:  $f_c = 4,000$  psi @ 28 Days Minimum
- 3.) Covers Available With Optional Plug Sizes Or Openings
- 4.) Pipe Openings Cored To Required Specifications
- 5.) 53 Gallons/Vertical Foot

Phoenix  
Precast  
Products

3' Diameter  
Dry Wells